

Suitable for condominium and office buildings.
For permanent user only!

In case of short time user (e.g. for offices, hotels, a.s.o.) technical adjustments are required. Contact WÖHR!

Platforms are in horizontal position to drive on.

Load per platform max. 2000 kg
(load per wheel max. 500 kg)

X = to be clarified with door supplier

Dimensions in cm

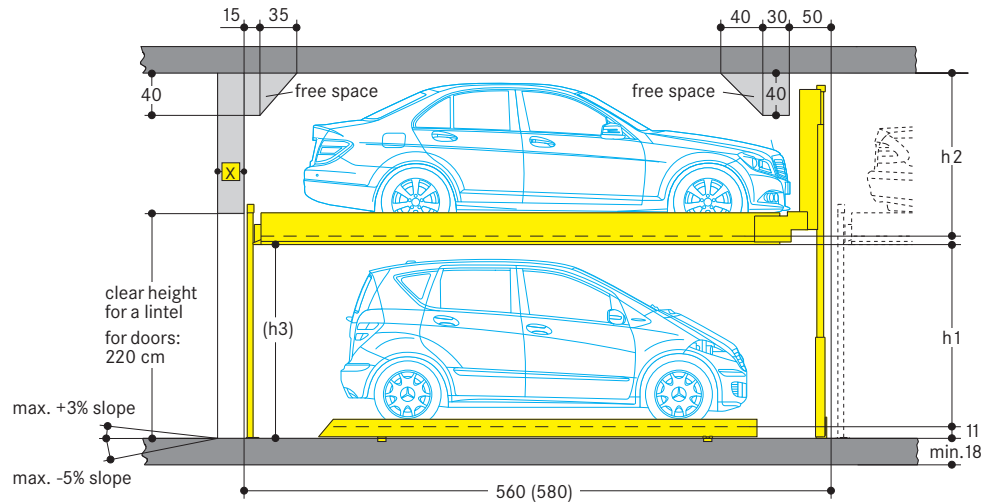

Standard type 552 · 2000 kg

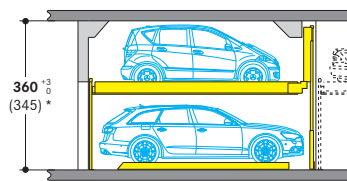

	car height	distance
UL	Cars/Station wagons up to 165 cm	h2 = 168
EL	Cars/Station wagons up to 165 cm	h1 = 170
UL = upper level, EL = entrance level		

Access height h3 = 181 cm.

* If cars and station wagons with a height of up to **150 cm** are parked on the **upper level**, a clear height of **345 cm** above the entrance level is sufficient.

Comfort type 552 · 2000 kg

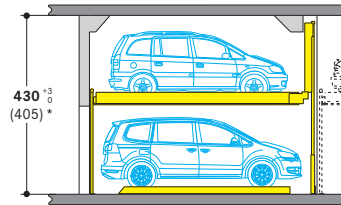

	car height	distance
UL	Cars/Vans up to 200 cm	h2 = 203
EL	Cars/Vans up to 200 cm	h1 = 205
Cars/Vans up to 2000 kg max.		

Access height h3 = 216 cm.

* If cars and vans with a height of up to **175 cm** are parked on the **upper level**, a clear height of **405 cm** above the entrance level is sufficient.

Compact type 552 · 2000 kg

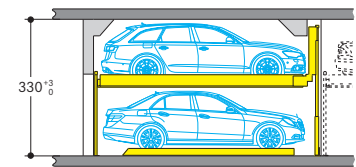

	car height	distance
UL	Cars/Station wagons up to 150 cm	h2 = 153
EL	Cars/Station wagons up to 150 cm	h1 = 155

Access height h3 = 166 cm.

Please attend to restricted car- and platform distance height!

Width dimensions

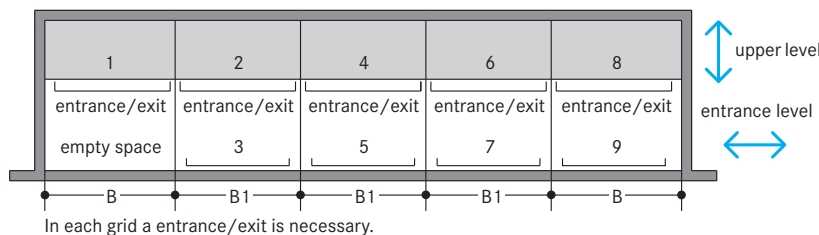

In each grid a entrance/exit is necessary.

Space required	gives clear	gives clear	
B	B1	platform width UL	platform width EL
260	250	230	207*
270	260	240	217*
280	270	250	227*
290	280	260	227*
300	290	270	227*

* the space to get in and out of the car for platforms in entrance level is increased by 35 cm driver side.

Notes

1. Installation length of 560 cm for car length of a max. of 500 cm. Clear platform width of 250 cm for car widths of 190 cm. For large touring sedans we recommend a clear platform width of at least 260–270 cm.
2. For very large cars an installation length of 580 cm is recommended. This length offers larger safety distances for potential future developments. Installation length of min. 580 cm for projects with short term parkers such as hotels or similar.
3. For 2 or 3 row arrangement min. platform width 250 cm.
4. For arrangement with Combilift 543 (542) doors are required.
5. It is not possible to have channels or undercuts and/or concrete haunches along the floor-to-wall joints. In the event that channels or undercuts are necessary, the system width needs to be reduced or the installation width needs to be wider.
6. The manufacturer reserves the right to construction or model modifications and/or alterations. Furthermore, the right to any subsequent part modification and/or variations and amendments in procedures and standards due to technical and engineering progresses in the art or due to environmental regulation changes, are also hereby reserved.

Grid arrangement

To guarantee visibility and for safety reasons, please consider the following maximum grid arrangement for 2 or 3 rows one behind the other.

2 rows one behind the other

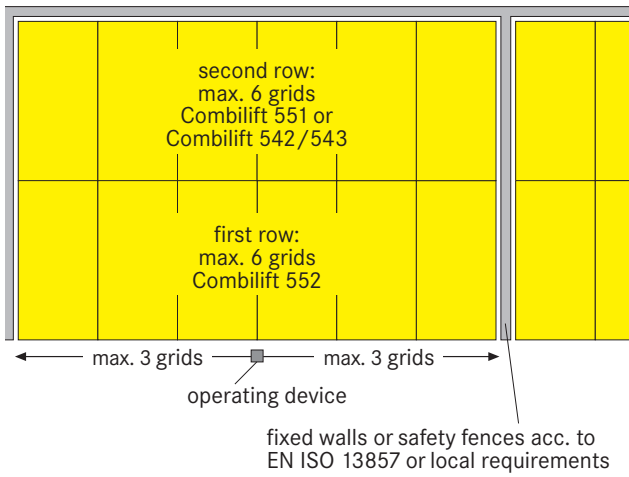

3 rows one behind the other

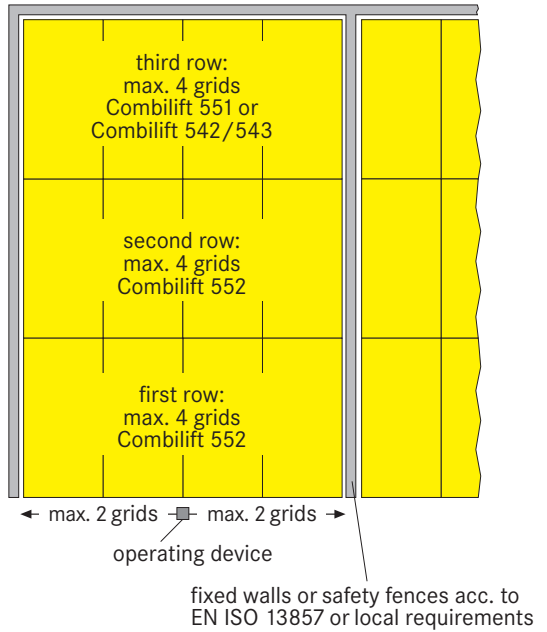

Design proposal: Combilift 552/Combilift 551 one behind the other

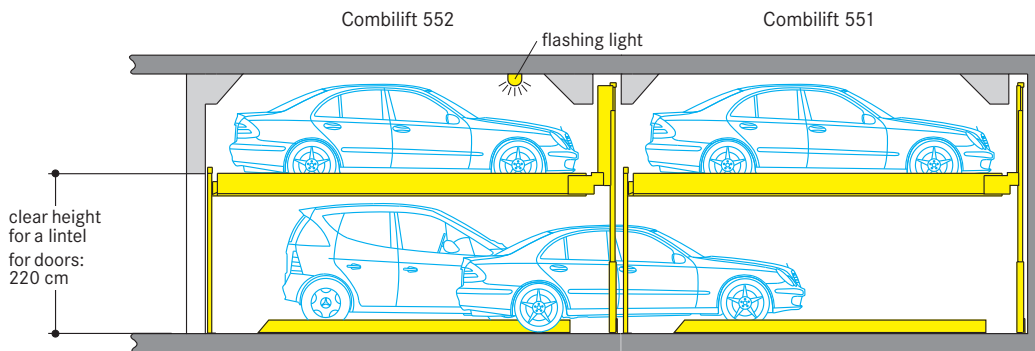

Design proposal: Combilift 552/Combilift 543 (542) one behind the other

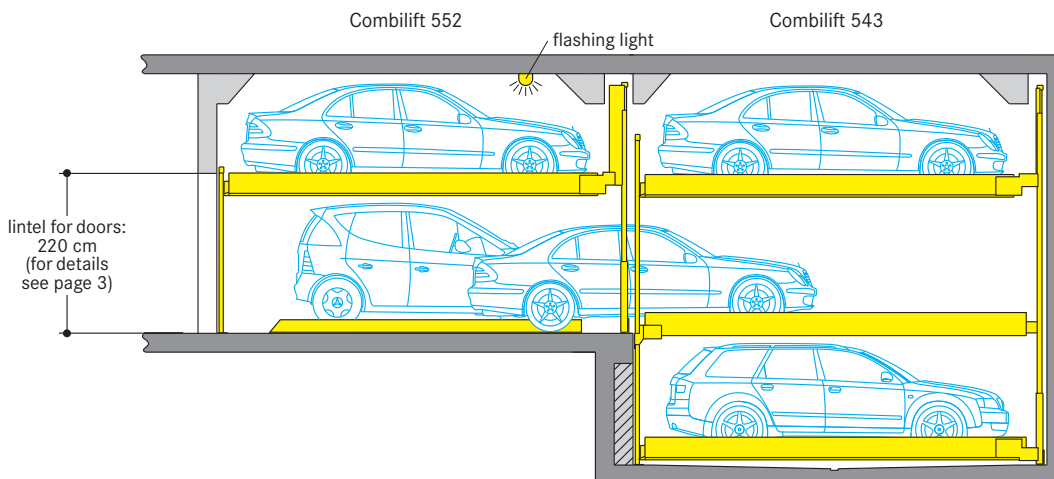

Doors (Combilift 552/Combilift 543 (542) one behind the other)

The door controls are integrated in the overall system. That means:

- The doors are electro-mechanically interlocked.
- The doors can only be opened when the selected parking place has reached the entry/exit position.

Local requirements for electrical doors regarding the technology, maintenance and revision are not subject of our delivery. These

matters have to be observed and carried out by the customer, according to the local regulations.

Door types:

Manually operated sliding shutterdoors with galvanized fence filling (also for above ground garages).

Alternatively, sliding shutterdoors can be supplied with electrical drive.

Installation:

Behind the building pillars with door offset

Section

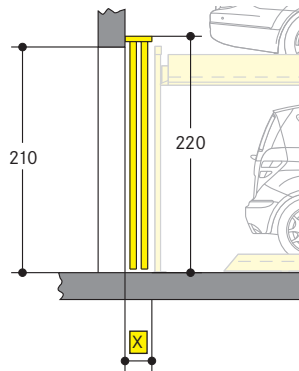

- X** = 25 cm for manually operated sliding shutterdoors
- X** = 35 cm for automatic shutterdoors

Installation:

Below the lintel between the building pillars

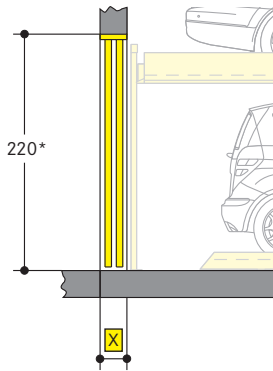

Installation:

In front of the building pillars

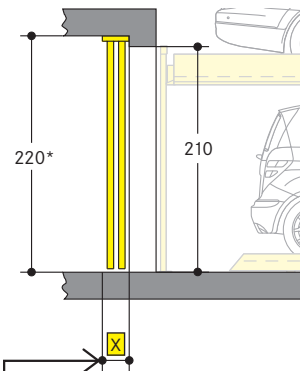

Ground plan

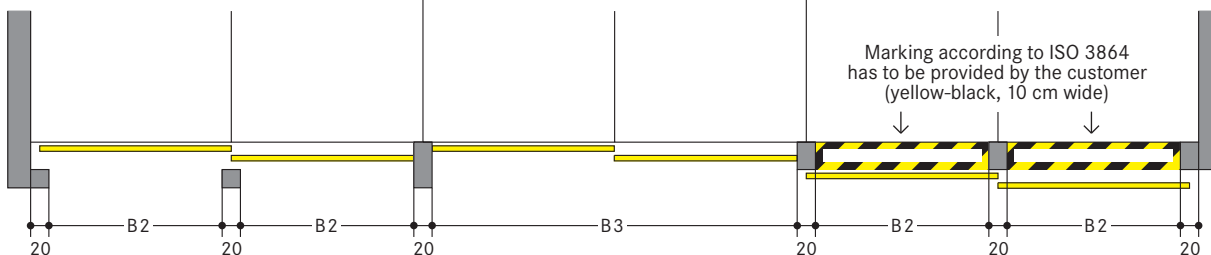

Space required		Gives clear platform width
B2	B3	
230	480	230
240	500	240
250	520	250
260	540	260
270	560	270

* The lintel of 220 cm is absolutely necessary. With differing heights, additional fixings are required at a surcharge. If no lintel is provided, the gates need to be fitted onto a steel frame (subject to surcharges).

Floor guide for sliding shutterdoors

Floor levelness in door guide range must be conformity with DIN 18202, table 3, line 3.

Hole depth for dowels approx. 8 cm.
Remark: When screed is applied in the door area to obtain floor levelness, the hole depth should be increased by screed thickness (max. 40 mm).

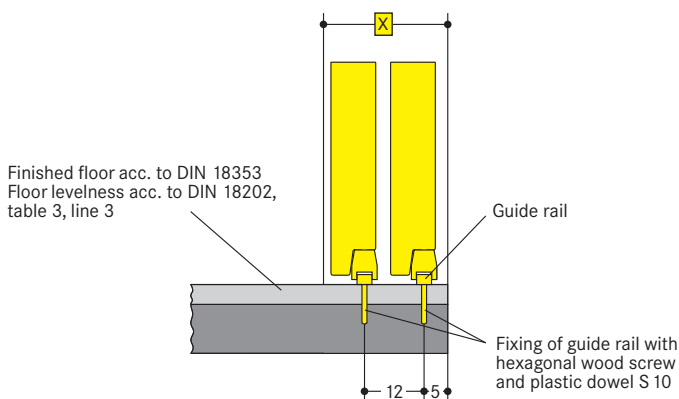

Evenness tolerances

According to EN 14010 the danger of trapping between nonparallel platforms edges and the ground has to be prevented. The distance between the lower flange of the platforms and the garage ground must therefore not exceed 2cm.

To adhere to the safety regulations and to get the necessary even ground, the tolerances of evenness to DIN 18202, table 3, line 3, must not be exceeded. Therefore exact levelling of the ground by the client is essential.

Abstract from DIN 18202, table 3

column	1	2	3	4	5	6
line	reference	Vertical measurements as limits in mm with measuring points distances in m to*				
		0,1	1	4	10	15
2	Unfinished to surface of covers, subconcrete and subsoils for higher demands, e.g. as foundation for cast plaster floor, industrial soils, paving tiles and slabstone paving, compound floor paving. Finished surfaces for minor purposes, e.g. warehouses, cellars	5	8	12	15	20
3	Finished grounds, e.g. floor pavement serving as foundation for coverings. Coverings, tile coverings, PVC flooring and glued coverings.	2	4	10	12	15

* Intermediate values are to be taken out the diagram and must be rounded-off to mm.

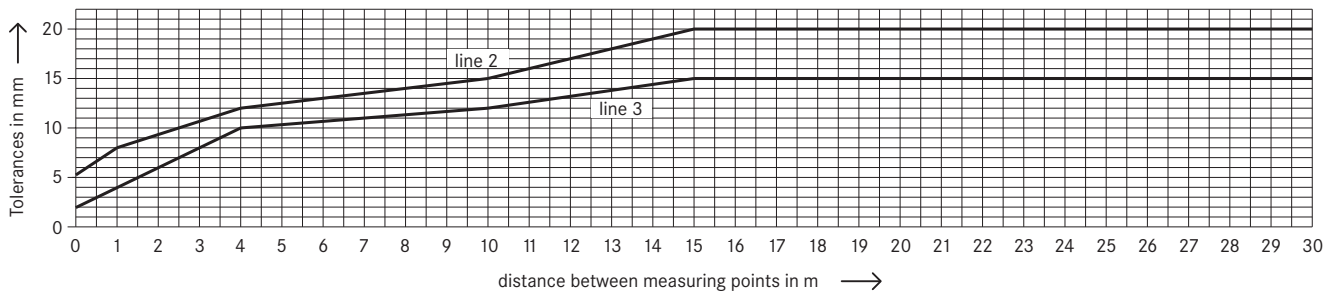

Check points

The evenness of a surface is checked independently of its position and slope by bore hole gauges between two check points on the surface. WÖHR normally make a random test using single measurements in case of obviously inaccurate surfaces.

For uniform examination of the evenness of the ground surface the following points are defined as measuring and check points:

- a) for surface recess.
- b) for finished floor.

a) Layout for surface recess width 4,40 m

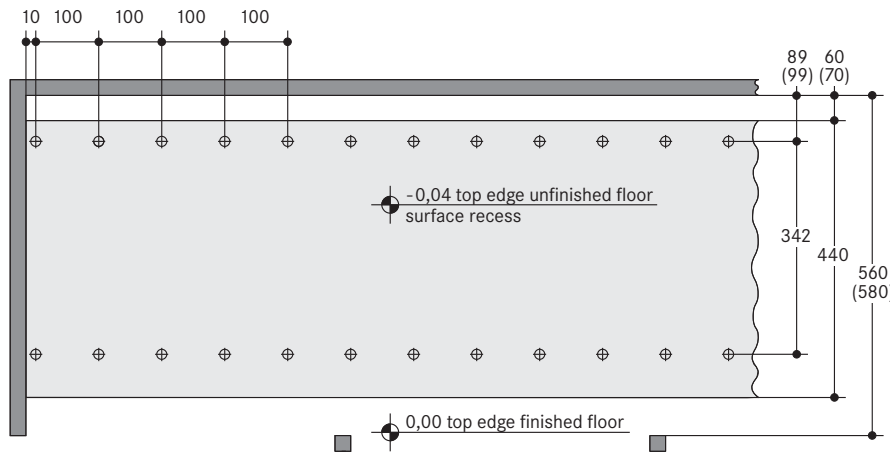

⊕ Measuring points at 100 cm points for checking the unevenness acc. to DIN 18202, table 3, line 2, or acc. diagram

() dimensions in brackets for increased length

b) Layout for finished floor after placing floor pavement

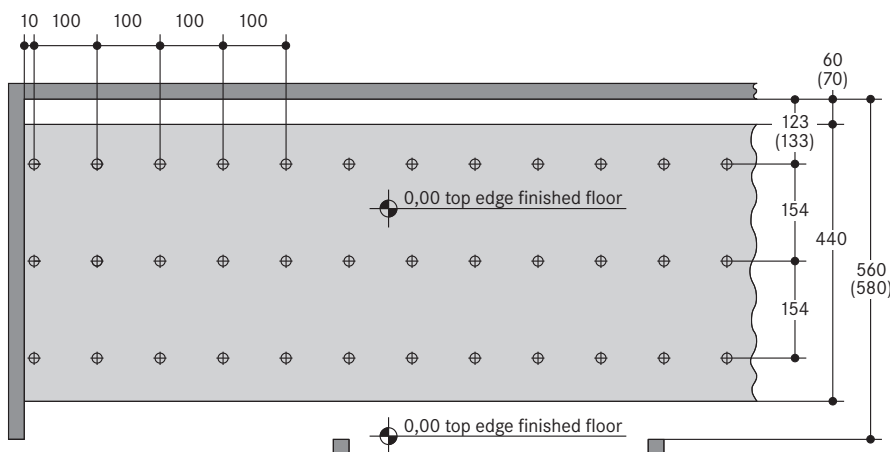

⊕ Measuring points at 100 cm points for checking the unevenness acc. to DIN 18202, table 3, line 3, or acc. diagram

() dimensions in brackets for increased length

Hydraulic power packs

For the accommodation of the hydraulic power packs an additional space is required which will be determined during the verifications of the drawings,

e.g. in a wall recess.
Dimensions:
length = 100 cm
height = 140 cm
depth = 35 cm

Electrical data

Main electrical supply 230/400V, 50 Hz, 3 phase. Power consumption 1.5/3.0 kW. Fuse or automatic circuitbreaker 3 x 16 A slow blow acc. to DIN VDE 0100 p. 430 and main supply line 3 Ph + N + PE (acc. to local power supply regulations) to the switch cabinet, provided by the

customer. In compliance with the DIN EN 60204 standard provisions, all systems must be connected directly on site with an earthed equipotential bonding. The lead-out connection must be at a 10 m distance!

Switch cabinet

1. Main switch is installed well accessible at driveway in a height of 160 cm to 190 cm.
2. The switch cabinet must be installed visible and near by the system. Area for installation has to be provided by the customer. The size of the switch cabinet is 80 x 110 x 21 cm.
3. The wall opening of 15 cm diameter is required between the switch cabinet and the system itself. Please contact Wöhr Agent to clarify.
4. The control is designed to operate between +5° and +40°C. Atmospheric Humidity: 50% at +40°C. If the local circumstances differ from the above please contact Wöhr (if necessary, the switch cabinet has to be provided with a heating).
5. If the system is installed outside the switch cabinet needs to be inside a sun-/water-/wind proof box. In front of the switch cabinet an area of 100 cm is required to work.

General product information

The combilift Type 552 consists of 2 platform rows, one above the other. In front (to the full width) of the installations is a drive way which is situated on the lower platform row (access level). The lower platform row consists of one platform less than the upper level. In order to access a platform on the upper level, the lower level

platforms (access level) shift laterally into the free space. The selected upper platform is now lowered vertically into the free space provided in the access level. The lowering of the platform is by means of push button control (hold-to-run-device), the hoisting of the platform is fully automatic.

Hotel garage

If used by hotel guests, the installation requires special planning and construction. Please ask for details.

Noise protection

Basis is the German DIN 4109 "Noise protection in buildings".

With the following conditions required 30 dB (A) in rooms can be provided:

- noise protection package from our accessory
- insulation figure of the construction of min. $R'_W = 57$ dB
- walls which are bordering the parking systems must be done as single wall and deflection resistant with min. $m' = 300$ kg/m²
- solid ceiling above the parking systems with min. $m' = 400$ kg/m²

At differing constructional conditions additional sound absorbing measures are necessary.

The best results are reached by separated sole plates from the construction.

Increased noise protection:

If increased noise protection must be provided planning has to be confirmed on a project basis by Wöhr (further building measures are required).

Temperature

The installation is designed to operate between +5° and +40°C. Atmospheric Humidity: 50% at +40°C. If the local circumstances differ from the above please contact Wöhr.

Numbering of the parking spaces

1. The empty space of the Combilift is always on the left in the entrance level.
2. The numbering is as follows:

UL	1	2	4	6	8
EL		3	5	7	9
3. The numbering for each system starts with 1 as above.
4. Different numbering of parking spaces is possible at a surcharge (software changes are necessary).

Conformity test

All our systems are checked according to EC machinery directive 2006/42/EC and EN 14010.

Illumination

Illumination has to be considered acc. to local requirements by the customer.

Free spaces

Special drawings for free spaces to accommodate air ducts or other pipes can be requested at Wöhr Agent!

Railings

If walkways are arranged directly to the side or behind the systems, railings have to be provided by the customer acc. to local requirements, height min. 200 cm - this is applicable during the construction phase too.

Maintenance

Regular maintenance by qualified personnel can be provided by means of an Annual Service Contract.

Protection against corrosion

Independent of a maintenance workings has to be carried out acc. to Wöhr Cleaning and Maintenance Instruction regularly.

Clean up galvanized parts and platforms of dirt and road salt as well as other pollution (corrosion danger)!

Pit must always be ventilated and deaerated well.

Parking place width

We recommend a clear platform width of at least 250 cm.

Dimensions

All dimensions shown are minimum. Construction tolerances must be taken into consideration. All dimensions in cm.

Fire safety

Each and every fire safety requirement and all possible mandatory item(s) and equipment(s) (fire extinguishing systems and fire alarm systems, etc.) are to be provided by the customer.

Clearance profile (standard saloon/estate car)

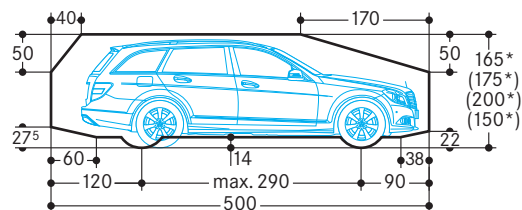

* The total car height includes roof rail and antenna fixture and must not exceed the mentioned max. height dimension.

Note

If doors are planned we recommend installing an empty pipe for cabling to the control panel from the rear. This empty pipe should be 120 cm above ground level in the centre of a column.